

Optical Fiber Cleaver

**FC-6C+**

Operation Manual

**IMPORTANT SAFETY PRECAUTIONS**

This product has been designed and manufactured to assure personal safety. Improper use can result in bodily injury and serious damage to the fiber cleaver. Please read and observe all warnings instructions given in this operation manual.



This symbol indicates explanations about dangerous matters. If users ignore this symbol and handle the cleaver the wrong way, bodily injury and damage to the cleaver could result.

1. Do not disassemble or lubricate any parts of the cleaver. Doing so can cause serious damage to the cleaver.
2. The FC-6C+ is a precision tool. Do not impact the cleaver by hitting or dropping it. Doing so can cause personal injury and loss of cleaving performance.
3. Glass fiber fragments are extremely sharp. Handle with care. Wear safety glasses at all times during cleaving operation for protection from glass fibers.
4. Dispose of glass fiber fragments properly. After use, please empty the off-cut bin and then store the cleaver in the case. There is a possibility that fiber offcuts could spill out of the bin during transportation if remain in the bin.
5. The blade of the cleaver is extremely sharp. Do not touch it with bare hands.
6. The FC-6C+ has the "automatic blade return" function. When the clamp cover is opened after cleaving, the blade carriage returns automatically to the forward. Be careful not to be hit your fingers by the blade or blade carriage.
7. Do not impact the top clamp lever and switching lever. Doing so can cause damage to the levers and loss of cleaving performance.
8. If the cleaver is damaged or a problem occurs, please contact our service department.

**1. General**

**Specification**

	FC-6C+
Cladding Diameter	125μm
Fiber Count	•Single fiber (φ0.25 & φ0.9mm)
Coating Diameter	•Up to 12-fiber ribbon
Cleave length	5~20mm (single φ0.25mm) 10~20mm (single φ0.9mm) 10mm (fiber ribbon)
Blade return function	Automatic return
Dimensions	100(W) x 86(D) x 63(H) mm
Weight	Approx. 430g

**Standard package**

Items	Qty.
Optical fiber cleaver FC-6C+	1 pc
Carrying case	1 pc
Fiber off-cut collector CU-FC6+	1 pc (pre-fitted)
Single fiber adapter AP-FC6M	1 pc (pre-fitted or attached)

**Optional accessories / Consumables**

Items	Name
Fiber off-cut collector	CU-FC6+
Single fiber adapter	AP-FC6M
Spare blade	FCP-20BL

**2. Structure**

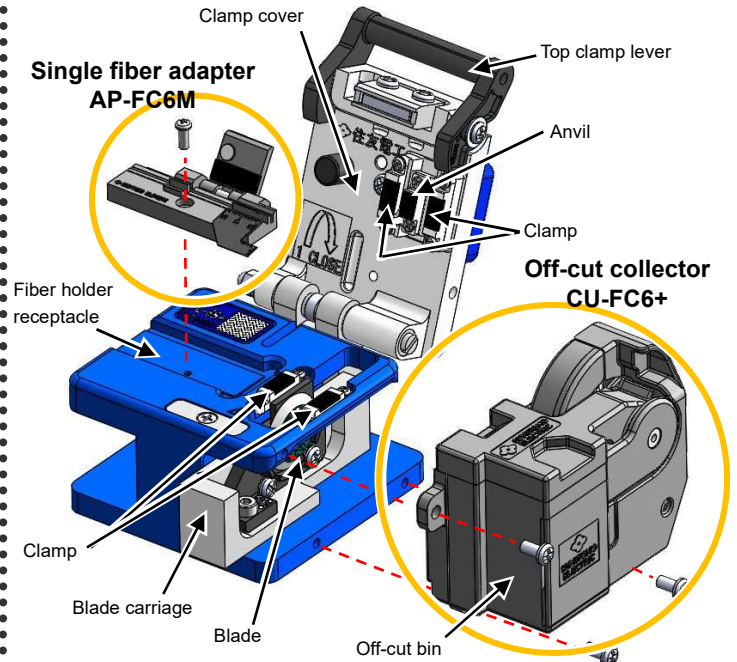

< Fiber cleaver FC-6C+ >

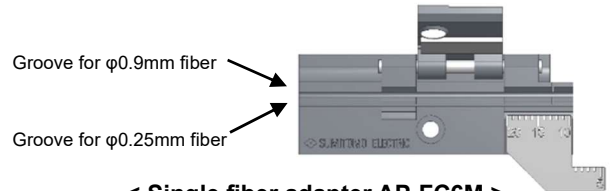

< Single fiber adapter AP-FC6M >

**3. Operating procedures**

**With single fiber adapter**

1: Open the top clamp lever and the lid of the single fiber adapter. The blade carriage should be in the forward position.

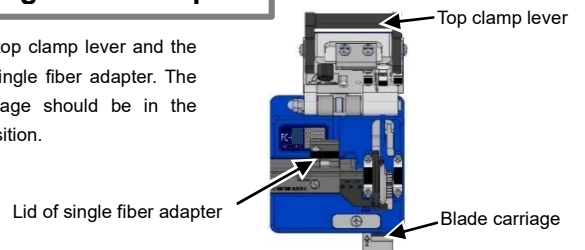

2: Lower the fiber straight into the correct V-groove with the end of the fiber coating (e.g. if the cleave length is 16mm) at the 16mm mark on the ruler.

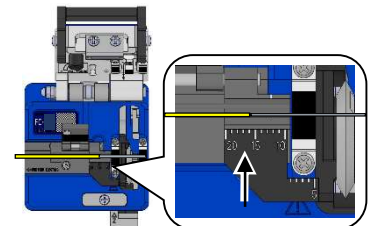

3: Close the lid of the single fiber adapter.

4: Lower the top clamp lever. Slide the blade carriage to the rear of the cleaver. The fiber will be cleaved.

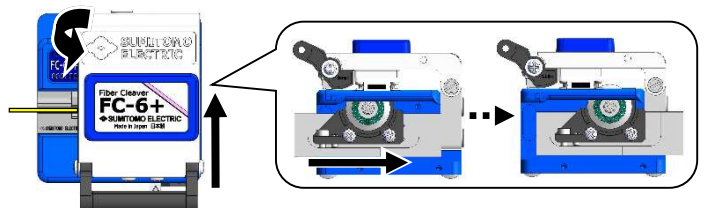

5: Open the top clamp lever. Then open the lid of the single fiber adapter and lift the newly cleaved fiber. Lift the off-cut and dispose it properly. (The FC-6C+ automatically collects an off-cut in the off-cut collector.) The blade carriage returns automatically after cleave, please refer "Automatic blade return function".

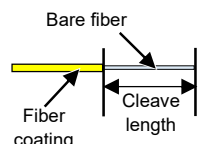

## With fiber holder

- 1: Open the top clamp lever. The blade carriage should be in the forward position.

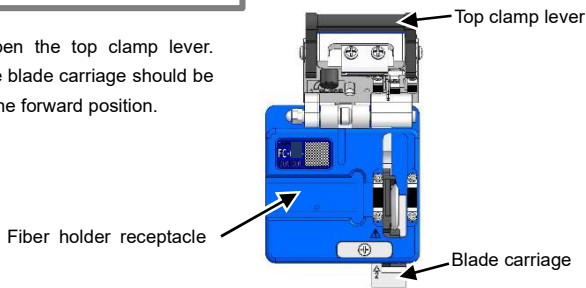

- 2: Place the fiber holder in the cleaver. Place the edge of the fiber holder against the edge of the fiber holder receptacle.

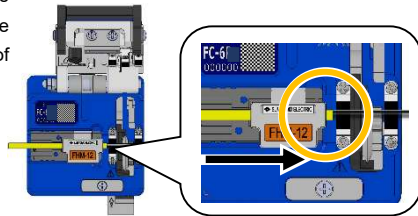

- 3: Lower the top clamp lever. Slide the blade carriage to the rear of the cleaver. The fiber will be cleaved.

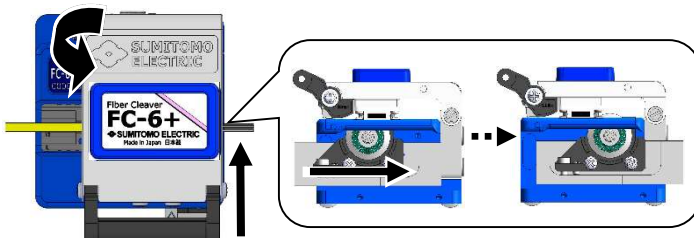

- 4: Open the top clamp lever. Remove the fiber holder from the cleaver. Lift the off-cut and dispose it properly. (The FC-6C+ automatically collects an off-cut in the off-cut collector.) The blade carriage returns automatically after cleave, please refer "Automatic blade return function".

## Automatic blade return function

The FC-6C+ has the "automatic blade return" function. When the clamp cover is opened after cleaving, the blade carriage returns automatically to the forward.

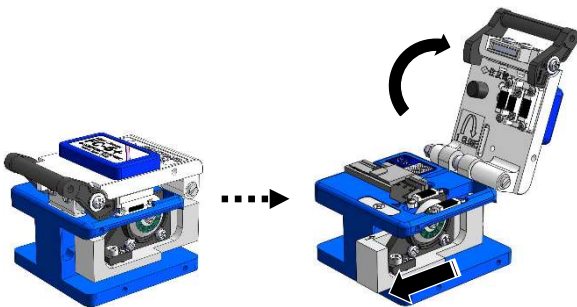

## 4. Maintenance

### Cleaning

To keep excellent cleaving quality, cleaning must be performed after use. Clean the blade edge, the rubber pad of the clamp and the anvil with a cotton swab moistened with isopropyl alcohol.

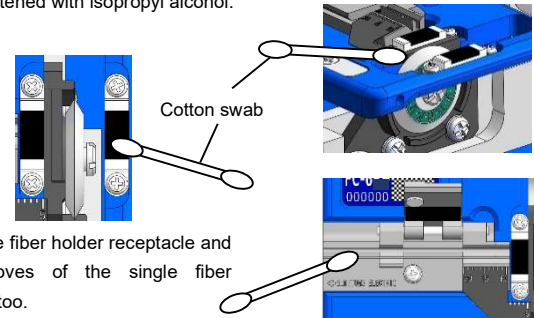

Clean the fiber holder receptacle and the grooves of the single fiber adapter, too.

- Dust on the blade edge or the clamp might cause loss of cleaving performance or poor quality of fiber end face.
- Do not clean them with any other kind of chemicals.
- If the top clamp lever is closed leaving an off-cut fiber on the clamp, the rubber pad of the clamp will have a trace of the fiber, causing loss of cleaving performance or poor quality of fiber end face.



Caution

### Blade position change

As the number of the cleave's increases, a symptom that fiber cannot be cleaved or cracks will occur. If such symptom continues to appear, the blade position is worn out. Rotate the blade according to the following procedures and use a new blade position.

[Reference] 2,250 fibers per position (\*)

(\*) The number above is not guaranteed. It may vary depending on the operating environment.

Remove the off-cut collector first.

- 1: Loosen the blade setscrew with a slotted screwdriver.

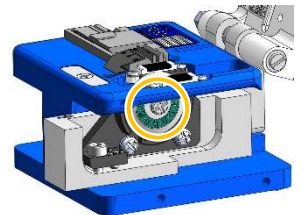

- 2: Rotate the blade to the next position by pressing its side or edge with a cotton swab.

Rotate the blade in the direction indicated by the arrow.

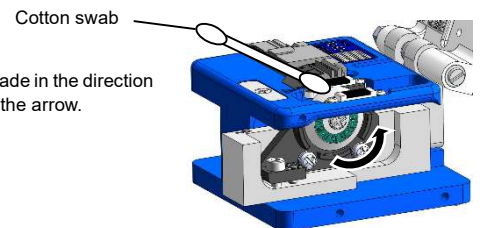

Caution

- Do not rotate the blade with hands.
- Do not rotate the blade with metallic tweezers. Doing so may damage the blade.

- 3: Tighten the blade setscrew.

[Reference] Optimum torque:  
Approx. 0.98N·m (10kgf·cm)

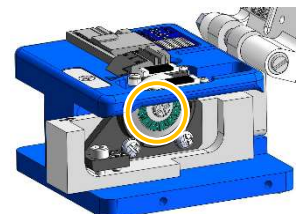

Caution

- Do not over-tighten the blade setscrew. The screw will get worn out.

- 4: Try and cleave the fiber. Make visual check of the fiber end face with the splicer. If the fiber end face is poor, adjust the blade height. (Refer to "Blade height adjustment".)

## Blade height adjustment

Remove the off-cut collector first.

1: Loosen the 2 cross head screws.

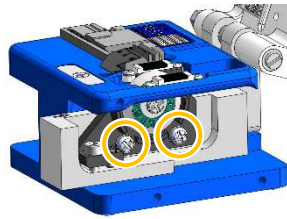

2: Slide the blade carriage to the rear of the cleaver, then loosen the blade height locking screw.

Put a Hex driver (US) or Allen key (UK) here.

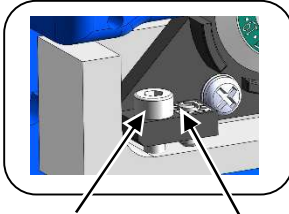

Blade height locking screw

Blade height adjustment screw

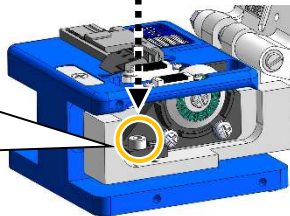

3: Place a mechanical pencil lead or a light stick on the clamps. Slide the blade carriage back and forth and turn the blade height adjustment screw. The point where the lead barely touches the edge of the blade is a reference point (0µm).

### ✓ Tips

- To make the blade higher, turn the blade height adjustment screw clockwise.
- To make the blade lower, turn the blade height adjustment screw anti-clockwise. (Turn the screw while pushing the blade down with a cotton swab.)

Mechanical pencil lead

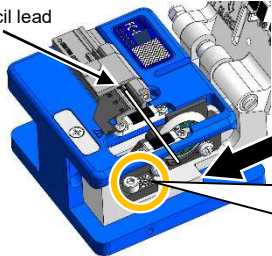

Slide the blade carriage.

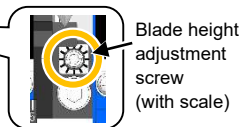

Blade height adjustment screw (with scale)

[Reference]

1 mark on scale = Approx. 10µm

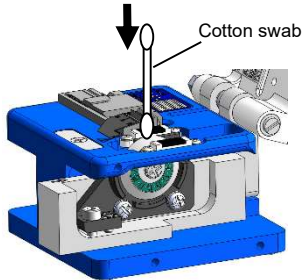

Cotton swab

To make the blade lower, turn the blade height adjustment screw anti-clockwise, while pushing the blade down with a cotton swab.

4: Turn the blade height adjustment screw clockwise by more 4 to 6 marks from the reference point.

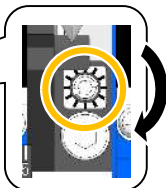
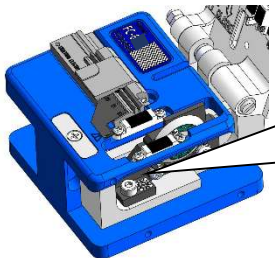

Caution

- Do not make the blade too high. Doing so will damage the anvil and increases the chipped fiber ends.

5: Tighten the blade height locking screw.

[Reference] Optimum torque: Approx. 0.59N·m (6kgf·cm)

6: Tighten the 2 cross head screws.

[Reference] Optimum torque: Approx. 0.98N·m (10kgf·cm)

## Blade replacement

Remove the off-cut collector first.

1: Unscrew the blade setscrew.

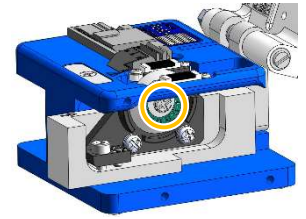

2: Remove the blade with tweezers.

Tweezers

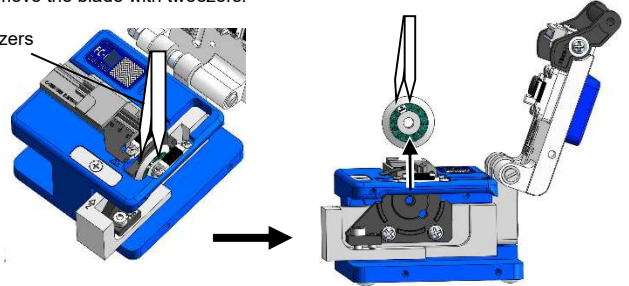

Caution

- The edge of a blade is manufactured precisely. If the edge is hit against metallic objects, it will crack, resulting in poor cleaving performance. Handle with care.
- When using metallic tweezers, be careful not to damage the blade.
- Do not touch the blade with hands. Use gloves.
- Dispose of the old blade properly.

3: Insert a new blade in the cleaver so that "(1)" of the number sticker is in the top position. (Refer to the enlarged view below.)

The hole of the blade should be aligned with the hole of the blade receptacle.

### Enlarged view

"(1)" should be in the top position.

(24) (1) (2)

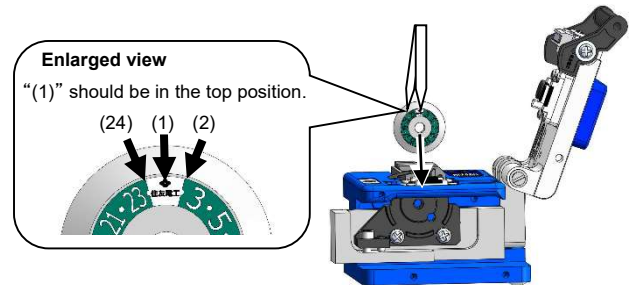

4: Tighten the blade setscrew completely, while pressing the side of the blade.

[Reference] Optimum torque: Approx. 0.98N·m (10kgf·cm)

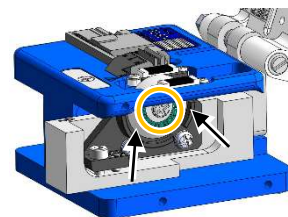

Press the side of the blade.

5: Adjust the blade height, referring to "Blade height adjustment".

## Troubleshooting

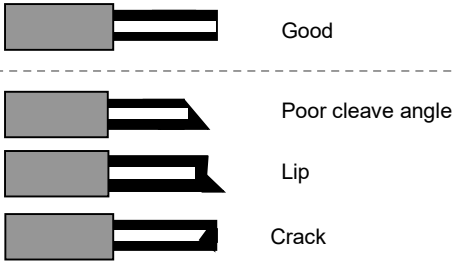

If the cleaving problem occurs, the followings are possible causes.

- (A) The fiber is placed obliquely in the cleaver.
  - ➔ Make sure that the fiber is placed straight in the cleaver.
- (B) The blade height is too high.
  - ➔ Adjust the blade height.
- (C) Dust or dirt remains on the clamp.
  - ➔ Clean the clamp.
- (D) Dust or dirt remains on the blade.
  - ➔ Clean the blade.
- (E) Dust or dirt remains on the fiber.
  - ➔ Remove the fiber coating and clean the bare fiber again.

If the problem still persists, please contact our service department.

## 5. Fiber off-cut collector

### Installing off-cut collector

- 1: Open the top clamp lever fully.
- 2: Put the lever pin into the pin hole of the cleaver

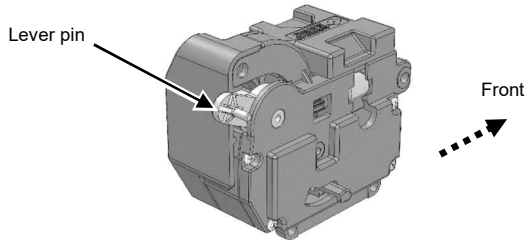

< Fiber off-cut collector CU-FC6+ >

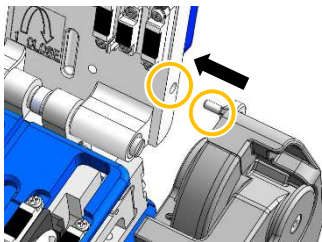

Put the lever pin into the pin hole of the cleaver.

- 3: Ensure that the lever pin and hook fit the cleaver properly.

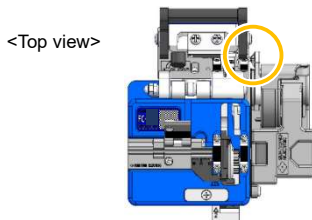

<Top view>

- 4: Align the screw holes on the cleaver with the screw holes on the off-cut collector.

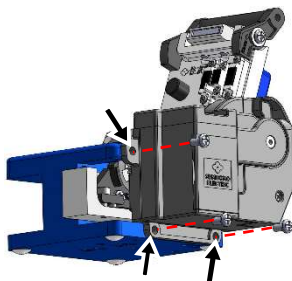

- 5: Tighten the 3 setscrews. Optimum torque: Approx. 40cNm.

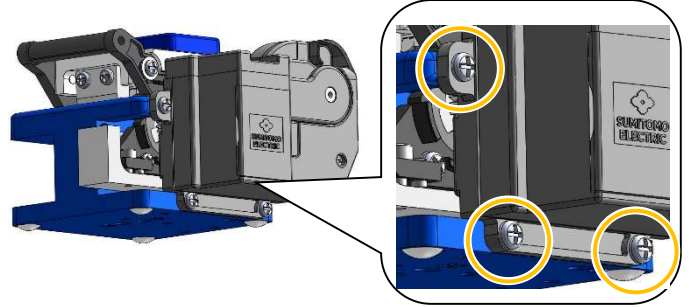

- 6: Completed.

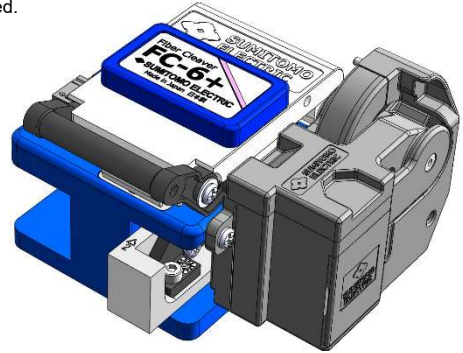

### Emptying off-cut collector

- 1: Remove the off-cut bin from the off-cut collector and dispose of the off-cuts in a proper way.

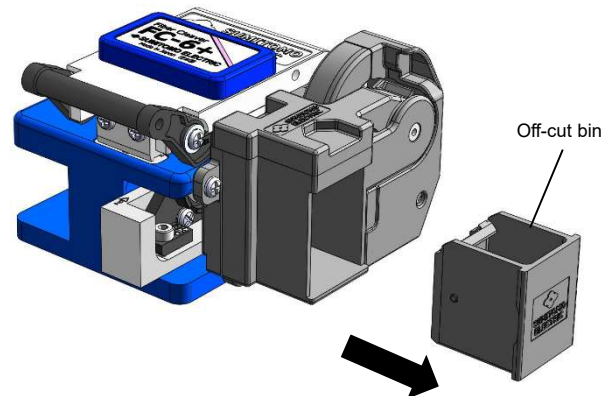

### Notice on Sumitomo genuine products



Caution

Please be very cautious of copy products that pretend Sumitomo genuine products.

For more information about counterfeit warning, please visit following website;

[https://global-sei.com/sumitomo-electric-splitters/counterfeit\\_warning/warning01.html](https://global-sei.com/sumitomo-electric-splitters/counterfeit_warning/warning01.html)



Tokyo (JAPAN)  
Sumitomo Electric Industries, Ltd.  
(Global Business Dept.)  
Akasaka Center Building, 1-3-13,  
Motoakasaka, Minato-ku, Tokyo  
107-8468, JAPAN  
Tel: +81 (0)3 6406 2666  
<http://global-sei.com/sumitomo-electric-splitters>

North Carolina (U.S.A.)  
Sumitomo Electric Lightwave Corp.  
201 South Rogers Lane, Suite 100  
Raleigh, NC27610 U.S.A.  
Toll Free No. 800 358 7378  
Tel: +1 919 541 8100  
<http://www.sumitomoelectric.com>

London (U.K.)  
Sumitomo Electric Europe Ltd.  
220 Centennial Park, Centennial Avenue,  
Elstree, Herts, WD6 3SL, U.K.  
Tel: +44 (0)20 8953 8118  
<http://www.sumielectric.com>

Hong Kong (China)  
Sumitomo Electric Asia, Ltd.  
Tel: +852 2576 0080  
<http://www.seac-cn.com>

Bangkok (Thailand)  
Sumitomo Electric (Thailand) Limited  
Tel: +66 (0)2 260 7231 to 5  
<http://www.sei-th.com/>

Singapore  
Sumitomo Electric Asia Pacific Pte. Ltd.  
Tel: +65 6261 3388  
<http://www.seps.com.sg/>

Dubai (U.A.E.)  
Middle East office  
Tel: +971 4 701 7338

Gurgaon (India)  
SEI Trading India Pvt. Ltd. (SETI)  
Tel: +91 124 4577 470

Manila (Philippines)  
SEI (PHILIPPINES) INCORPORATED  
Tel: +63 2 811 2755/2756